

www.screen2crush.com

Your online source for

Screens, Trommels, Jaw Crushers, Cone Crushers, Impact Crushers, HSI & VSI Crushers, Tub Grinders, Horizontal Grinders, Slow Speed Shredders, Radial Stacking Conveyors, Picking/Recycling Stations, Screening/Crushing bucket attachments and Material Washing Systems.

NEW EQUIPMENT BRANDS WE CARRY:

MCCLOSKEY INTERNATIONAL, LIPPMANN-MILWAUKEE, COREX, FLIP SCREEN, EZ SCREEN, TRACK STACK, EMS PICKING STATION

PREVIOUSLY OWNED BRANDS IN STOCK:

Allu, Anaconda, Astec, Backhus, Bandit, Boliden Allis, CDE Global Wash Systems, CEC, Cedarapids, Corex, Diamond Z, Doppstadt,

EMS, Extec, EZ Screen, Finlay, Fintec, Flip Screen, HogZilla, JCI-KPI, Keestrack, Kolberg, Lippmann, McCloskey, Metso, Morbark, Nordberg, Pegson, Peterson, Powerscreen, Royer, S2C, Sandvik, Screen USA, Striker, Telsmith, Terex, Trackstack, Triman, Trio.

Please Click on the text to be directed to our website: www.screen2crush.com

APRIL 2011



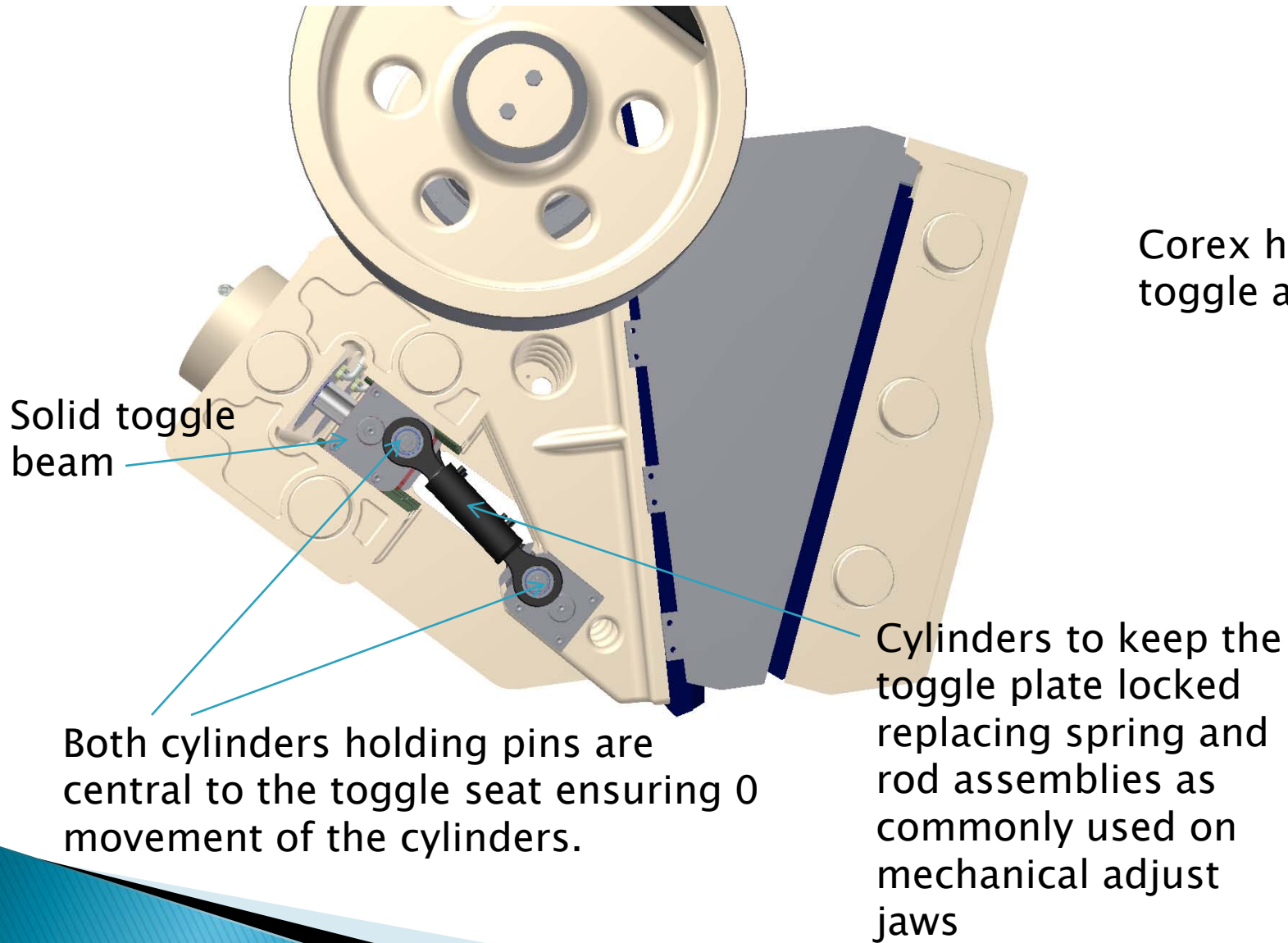

Corex hydraulic toggle assy.

Cross sectional view of Hydraulic toggle

ROTASTROKE unique to COREX jaws 1 ½ (38mm) and 7/8 (18mm)

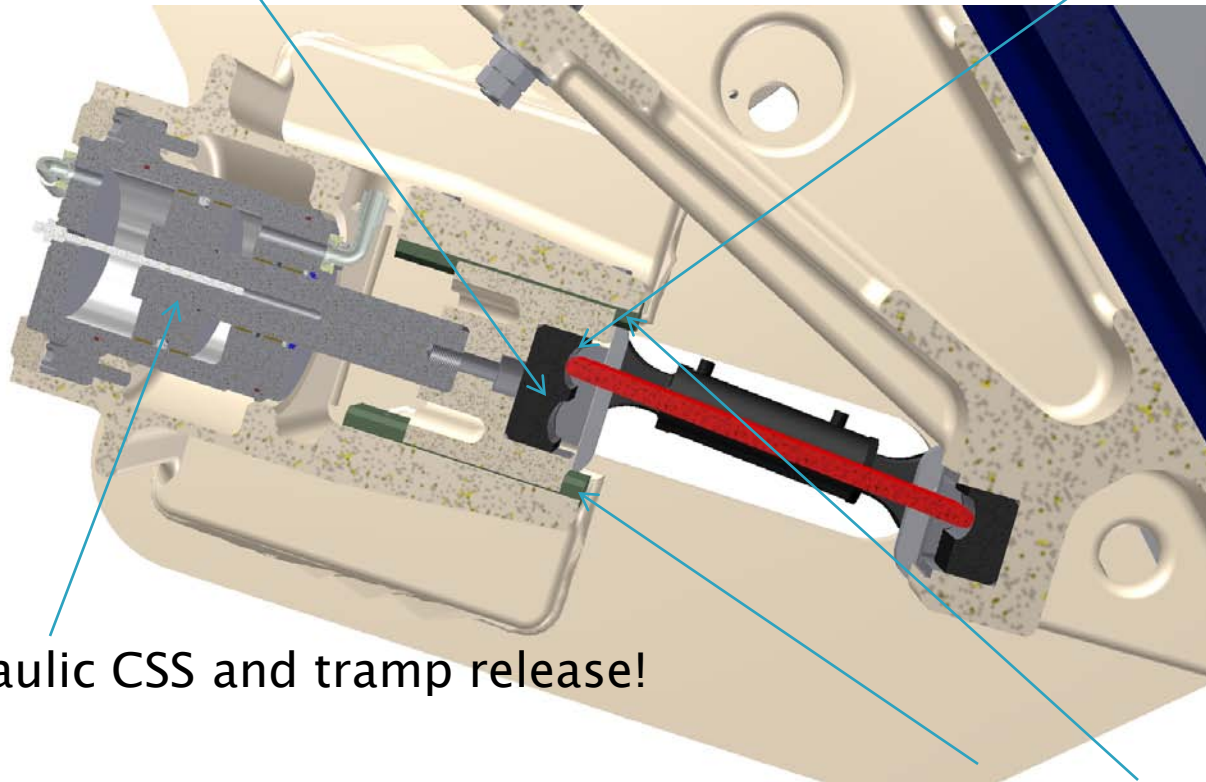

Hydraulic CSS and tramp release!

Replaceable slide wear strips
(Lubricated)

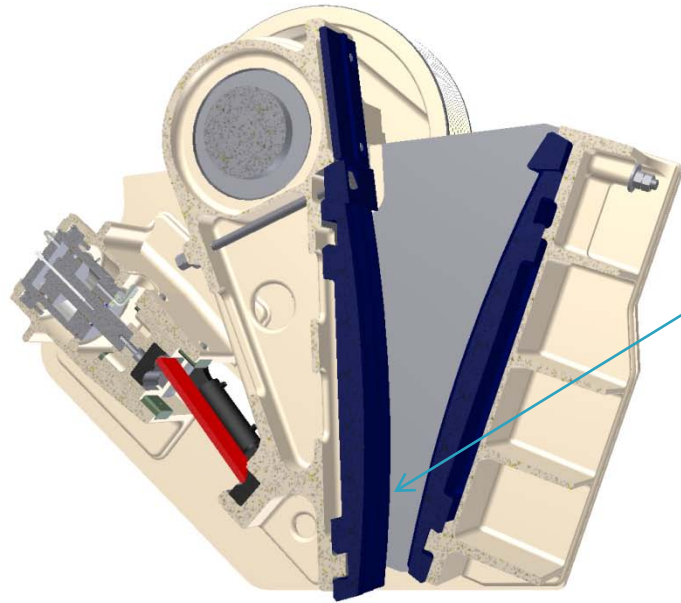

Tramp release open

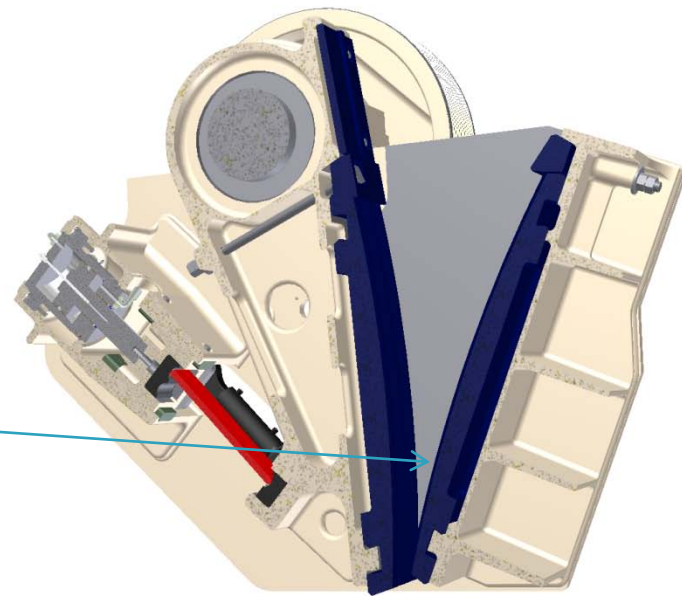

CSS closed.



ALL COREX JAWS HAVE HYDRAULIC CSS AND TRAMP RELEASE.
ALL ADJUSTMENTS ARE DONE ON ONE EASY TO OPERATE
TOUCH SCREEN.

ROTA-STROKE IS UNIQUE TO COREX, THE STROKE OF THE JAW
MAY BE CHANGED BY SELECTING ONE OF TWO POSITIONS ON
THE TOGGLE SEAT 38MM FOR HIGH PRODUCTION COARSE
MATERIAL AND 18MM FOR REDUCE PRODUCTIN FINE
MATERIAL REDUCING THE NEED FOR SECONDARY CRUSHING
IN SOME APPLICATIONS.

FOR FURTHER INFORMATION CONTACT A COREX
REPRESENTATIVE

www.screen2crush.com