



Facts:

- World's most commonly used turner series
- Comfortable and easily accessible panoramic cabin
- Easy access for routine maintenance and service
- Long list of standard features
- Outstanding performance for professional application

BACKHUS 17-series

The choice of composting pros. Small fuel consumption and large turning capacities. The largest variety of options allow individual solutions for each customer. No matter what windrow width you choose, BACKHUS' low maintenance and great efficiency continue to set industry standards.





technical data

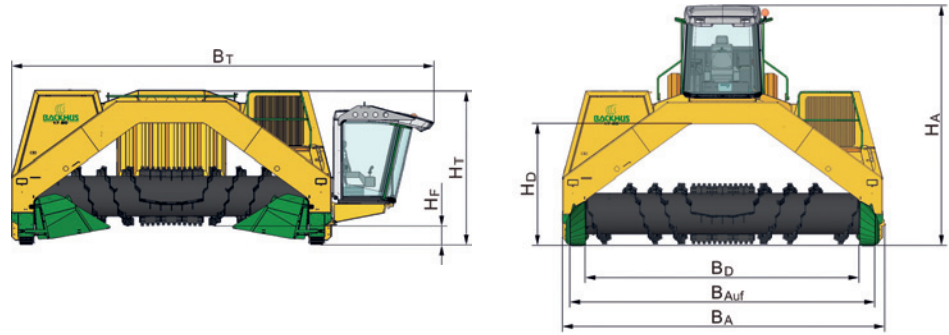

BACKHUS North America Inc.
17 Battery Place
Suite 1307
New York, NY 10004, USA

☎ 212 488 1772
☎ 800 586 8330
☎ 212 488 1774
✉ sales@backhus.us
🌐 www.backhus.us

Find out more:
www.backhus.us/17-series

17-series			17.43	17.50	17.55	17.60
working data						
heap width up to	BAuf	ft	14	16	18	20
heap height up to		ft	6.9	7.9	8.2	8.5
heap cross section at 45 deg		yd ²	5.5	7.4	9.0	10.6
turning capacity up to		yd ³ /h	3,700	4,700	5,200	6,000
forward feed speed		ft/min	0-200	0-160		0-130
dimensions work						
clearance width	BD	ft	12.3	14.6	16.2	17.8
clearance height	HD	ft	6.2	7.2	7.5	7.9
length		ft	16.9			
width	BA	ft	15.4	17.7	19.4	21.0
height	HA	ft	13.9	14.9	15.3	15.6
dimensions transport						
length		ft	8.4			
width	BT	ft	21.6	24.8	26.4	28.1
height	HT	ft	10.2			
ground clearance max.	HF	inch	18		13.8	
engine						
engine			Cummins QSB; 6.75 lt; 6 cylinders	Cummins QSC; 8.30 lt; 6 cylinders		Cummins QSL; 8.90 lt; 6 cylinders
power		HP	205	280		325
weight approx.		lbs	19,900	23,800	26,000	27,600